

**COUNTY OF SAN MATEO  
PLANNING AND BUILDING DEPARTMENT**

**DATE:** April 1, 2021

**TO:** Zoning Hearing Officer

**FROM:** Planning Staff

**SUBJECT:** Consideration of a Non-Conforming Use Permit, pursuant to Section 6411 and 6137 of the County of San Mateo Zoning Regulations, for the revised plan to construct a bicycle storage shed in the front half of a non-conforming parcel and exceed maximum floor area ratio by 92 square feet. The project is located at 573 Menlo Oaks Drive in the unincorporated Menlo Oaks area of San Mateo County, and was continued from the meeting held February 4, 2021.

County File Number: PLN 2020-00311 (Wood)

**PROPOSAL**

The applicants, requesting a continuance from the February 4, 2021 hearing, have proposed a modified design, in response to community comments, to construct a 98 sq. ft. bicycle storage shed behind the existing two-car carport located within the front half of the non-conforming 10,133 sq. ft. parcel (where 20,000 sq. ft. is the minimum parcel size). The modified design will continue to exceed the maximum parcel floor area ratio of 30% (3,039 sq. ft.) by 92 sq. ft. for a floor area ratio of 31% (3,130 sq. ft.). The location of the detached shed does not conform to the detached accessory building regulations that require the shed to be in the rear half of an improved parcel. Despite the modified design, the non-conforming use permit is needed to allow for the revised location behind the existing carport, in the front yard setback and to exceed floor area ratio. No trees are proposed for removal.

**RECOMMENDATION**

That the Zoning Hearing Officer approve the Non-Conforming Use Permit (County File Number PLN 2020-00311), by making the required findings and adopting the conditions of approval included in Attachment A.

**BACKGROUND**

Report Prepared By: Bryan Albini, Project Planner; [balbini@smcgov.org](mailto:balbini@smcgov.org)

Applicant/Owner: Danielle and Eric Wood

Location: 573 Menlo Oaks Drive, Menlo Oaks

APN: 062-140-160

Size: 10,133 sq. ft.

Existing Zoning: R-1/S-100 (Single-Family Residential District/ S-100 Combining District with 20,000 sq. ft. minimum parcel size)

General Plan Designation: Low Density Residential (0.3 to 2.3 dwelling units per acre)

Sphere-of-Influence: Menlo Park

Existing Land Use: Single-Family Residence

Water Supply: California Water Service – Bear Gulch

Sewage Disposal: West Bay Sanitary District

Flood Zone: Zone X (Area of Minimal Flooding), Map page 06081C0308E; effective date October 16, 2012.

Environmental Evaluation: Categorically exempt from the California Environmental Quality Act (CEQA) Guidelines, pursuant to Section 15303, Class 3, related to the construction of accessory (appurtenant) structures.

Setting: The project site is located on a flat developed parcel in a residential neighborhood in Menlo Oaks, an unincorporated community adjacent to Menlo Park. There is an existing residence and detached carport in the front yard. Adjacent lands are developed with single-family residences.

Chronology:

<u>Date</u>	<u>Action</u>
May 2020	- Property owners begin construction on 98 sq. ft. bicycle shed next to existing detached carport constructed in August 2020 (BLD 2017-02349).
June 2020	- Construction halted after concerns from neighbor about permitting.
September 17, 2020	- Use Permit application submitted to allow for an accessory structure in the front half of a residentially parcel 92 sq. ft. area (PLN 2018-00347).
February 4, 2021	- Zoning Hearing Officer Meeting. Applicant requested a continuance to provide alternative site plan in response to public opposition.

February 25, 2021 - Revised site plan provided by applicant.

April 1, 2021 - Zoning Hearing Officer Meeting.

## **DISCUSSION**

### **A. KEY ISSUES**

#### **1. Conformance with the General Plan**

Staff has determined that the proposed project complies with all applicable County General Plan policies, specifically:

Policy 4.36 (*Urban Area Design Concept*) and Policy 8.15 (*Land Use Compatibility*) seek to maintain and improve upon the appearance and visual character of development in urban areas, ensure that proposed development contributes to the orderly and harmonious nature of the locality, and protect and enhance the character of existing single-family areas.

The revised design involves the construction of 98 sq. ft. enclosed bicycle storage shed behind the existing detached carport in the front half of a non-conforming parcel. The structure would be approximately 43 feet from the front property line, more than the 40 feet setback required for structures in the R-1/S-100 zoning district. While there is no distinct design theme for this area of Menlo Oaks, surrounding development includes one- and two-story residences with a mix of stucco and wood siding, traditional and modern style roofs, and two-car garages. The construction of the proposed accessory storage structure does not change the existing single-family residential use and will use materials and colors that match the existing residence's exterior color and materials.

In addition, Policy 8.35 (*Zoning Regulations*) and Policy 8.36 (*Uses*) aims to regulate urban uses by providing development standards that are consistent with the overall land use designation. The revised location of the proposed accessory structure will be compatible with the neighborhood and adhere to all applicable regulations with the exception of the left side yard setback and parcel floor area.

#### **2. Conformance with the Zoning Regulations**

The project conforms with the following applicable Zoning Regulations:

##### **a. Development Standards**

The project parcel is zoned R-1/S-100 (Single-Family Residential District/S-100 Combining District). The legal 10,133 sq. ft. parcel is non-conforming for lot width and building lot area and is improved with a 3,032 sq. ft. two-story residence and 400 sq. ft. detached carport. The

residence and carport were approved under a previous use permit (PLN 2016-00104) to allow for reduced side yard setbacks and the detached carport in the front half of the parcel that was completed in early 2020 (BLD 2017-02349). The proposed 98 sq. ft. bicycle storage building will be non-conforming for the location in the front half of the residential parcel and will increase the total calculated floor area on the parcel to exceed the maximum allowed by 0.8% to 3,130 sq. ft. (where 3,039 sq. ft. is the maximum allowed for a parcel of this size). The proposed development would otherwise comply with all other required development standards for the R-1/S-100 Zoning District as outlined in the tables below.

<b>S-100 District Development Standards</b>			
	<b>Required</b>	<b>Existing</b>	<b>Proposed</b>
Minimum Lot Width	Average 75 ft.	43.42 ft.*	<i>No Change</i>
Minimum Building Area	20,000 sq. ft.	10,133 sq. ft.*	<i>No Change</i>
Minimum Front Yard Setback	40 ft.	125 ft. 5 in.	<i>No Change</i>
Minimum Side Yard Setback	10 ft.	4 ft.* (Left) 6 ft. 6 in.* (Right)	<i>No Change</i>
Minimum Rear Yard Setback	20 ft.	33 ft. 8 in.	<i>No Change</i>
Maximum Lot Coverage <sup>1</sup> (All Development)	25% (2,533 sq. ft.)	22% (2,278 sq. ft.)	23% (2,374 sq. ft.)
Maximum Floor Area Ratio <sup>2</sup> (All Development)	30% (3,039 sq. ft.)	29% (3,032 sq. ft.)	31% (3,130 sq. ft.)
Maximum Building Height	30 ft.	20 ft. 10 ¾ in.	<i>No Change</i>
<p><i>*Non-conforming.</i></p> <ol style="list-style-type: none"> <li><i>1. Lot Coverage includes residence (1,878 sq. ft.) and detached carport (400 sq. ft.) with proposed accessory structure (94 sq. ft.).</i></li> <li><i>2. Floor Area Ratio calculation includes residence (3,032 sq. ft.) and proposed accessory structure (94 sq. ft.). Detached carport (400 sq. ft.) and sub-grade basement (303 sq. ft.) not included.</i></li> </ol>			



Detached Accessory Building Development Standards			
	Required	Existing Carport	Proposed Shed
Maximum Floor Area of Rear Yard Area	30% (1,519 sq. ft.)	7% (400 sq. ft.) In Front Yard	9% (498 sq. ft.) In Front Yard**
Maximum Floor Area	1,000 sq. ft.	400 sq. ft.	498 sq. ft.
Maximum Plate Height	10 ft.	9 ft.	8 ft. 10 in.
Minimum Front Yard Setback	Not Allowed	40 ft.	36 ft.
Minimum Left Side Yard Setback	3 ft.	19 ft. 7 in.	5 ft.
Minimum Right Side Yard Setback	3 ft.	5 ft.	25 ft.
Minimum Rear Yard Setback	3 ft.	164 ft.	157 ft.
Minimum Distance From Residence	5 ft.	68 ft. 10 in.	62 ft.
<i>**Proposal requiring a non-conforming use permit.</i>			

The S-100 Zoning District development standards require that the maximum allowed floor area for a parcel exceeding 10,000 sq. ft. is 30%, or 3,039 sq. ft. Section 6411(b) from Chapter 22 (General Provisions and Exceptions) of the San Mateo County Zoning Regulations also requires detached accessory buildings to be located in the rear half of the parcel. With the exception of the location of the storage structure, and the floor area exceeding the maximum allowed in the district by 92 sq. ft., the project meets applicable zoning regulations.

The applicants, in response to public comments received at the previous February 4, 2021 Zoning Hearing Officer meeting, have proposed a new design for a structure that is more in compliance with regulations. However, the new design will still require a non-conforming use permit for the detached storage structure location in the front yard and to exceed maximum floor area allowed, due to the non-conforming width and size of the parcel.

3. Conformance with Non-Conforming Use Permit Regulations

The subject parcel is non-conforming as identified in Section 2.a. above., Section 6137 (*Exceptions*) allows applicants to request a non-conforming use permit to construct new development that does not conform with the zoning regulations, as is being proposed under the subject application. Therefore, the following findings, as required by Section 6137, must be made:

- a. **That the proposed development is proportioned to the size of the parcel on which it is being built.**

The subject property is a legal parcel of substandard size for the S-

100 Zoning District, and was improved with a 3,032 sq. ft. single-family residence, under the maximum floor area allowed of 3,039 sq. ft.

As discussed in 2.a., the proposed 98 sq. ft. detached accessory structure is non-conforming due to its location in the front yard. The applicants chose this location due to proximity to the existing carport and the ability to accessibly store and secure bicycles and equipment.

Aside from the bicycle storage structure location and the increase in allowable floor area, the proposed development is proportional with the lot coverage limits and setbacks required by the applicable zoning district.

- b. That all opportunities to acquire additional contiguous land in order to achieve conformity with the zoning regulations currently in effect have been investigated and proven to be infeasible.**

Surrounding properties are currently developed and used as single-family residences and are under separate ownership. The subject parcel is bordered on the left by an access easement serving the flag lot property directly behind the subject parcel, while the parcel to the right is a non-conforming parcel of substandard size improved with a structure with conforming side yard setbacks. Acquiring additional lot area to make the project compliant would not be feasible, nor would it address the location criteria of the accessory structure.

- c. That the proposed development is as nearly in conformance with the zoning regulations currently in effect as is reasonably possible.**

The proposed project is nearly in compliance with the applicable zoning regulations as is reasonably possible. Despite exceeding allowable floor area in the district by 92 sq. ft., the accessory structure will serve only as a bicycle storage building next to the existing carport, and no change to total habitable floor space will occur. While there is sufficient space in the rear yard to place the detached structure in compliance with Section 6411(b), the location of the detached structure in the front yard allows the residents to securely store bicycles next to the vehicles under the existing carport.

- d. That the establishment, maintenance and/or conducting of the use will not, under the circumstances of the particular case, result in a significant adverse impact to coastal resources, or be detrimental to the public welfare or injurious to property or improvements in said neighborhood.**

As proposed and conditioned, Staff has determined that the proposed detached accessory structure does not impact the public welfare or cause detriment to property or improvements in the neighborhood. The increased floor area incurred by the detached storage building is feasible due to no net increase in habitable floor area, and due to its non-conforming width and size, the property does not have an enclosed garage for storage as neighboring properties do.

Furthermore, the project site is not located within the Coastal Zone and therefore does not generate a significant adverse impact to coastal resources.

**e. That the use permit approval does not constitute a granting of special privileges.**

Approval of a non-conforming use permit does not constitute the granting of a special privilege as Chapter 4 (*Zoning Non-Conformities*) of the San Mateo County Zoning Regulations provides the same exception process for similar properties under the same development constraints. The parcels in the area are a mixture of rectangular and flag lots, with most not meeting minimum lot width and sizes required by the district.

**B. ENVIRONMENTAL REVIEW**

This project is categorically exempt from the California Environmental Quality Act (CEQA) Guidelines, pursuant to Section 15303, Class 3, related to the construction of accessory (appurtenant) structures on a site in an urbanized area, zoned for residential use.

**C. REVIEWING AGENCIES**

Building Inspection Section

**ATTACHMENTS**

- A. Recommended Findings and Conditions of Approval
- B. Vicinity Map
- C. Project Plans
- D. Street View
- E. Staff Report from February 4, 2021 Zoning Hearing Officer meeting

BRA:cmc – BRAFF0511\_WCU.DOCX

County of San Mateo  
Planning and Building Department

**RECOMMENDED FINDINGS AND CONDITIONS OF APPROVAL**

Permit or Project File Number: PLN 2020-00311

Hearing Date: April 1, 2021

Prepared By: Bryan Albini,  
Project Planner

For Adoption By: Zoning Hearing Officer

**RECOMMENDED FINDINGS**

For the Environmental Review, Find:

1. That the project is categorically exempt from the California Environmental Quality Act (CEQA) Guidelines, pursuant to Section 15303, Class 3, related to the construction of accessory (appurtenant) structures on a site in an urbanized area, zoned for residential use.

For the Non-Conforming Use Permit, Find:

2. That the establishment, maintenance and/or conducting of the use will not, under the circumstances of the particular case, result in a significant adverse impact to coastal resources, or be detrimental to the public welfare or injurious to property or improvements in said neighborhood, as the site is not located within the Coastal Zone and the proposed project generates negligible impacts on adjacent parcels and the surrounding neighborhood. The front yard location and floor area increase will allow for a proportionately sized bicycle storage building, offering transportation alternatives to the residents.
3. That the proposed development is proportioned to the size of the parcel on which it is being built, as the decreased setbacks allow for minimized visual impact and the location of the carport allows for the proposed residence to be of proportional size to the substandard parcel. The proposed structure complies with maximum lot coverage limits of the applicable zoning district.
4. Surrounding properties are currently developed and used as single-family residences and are under separate ownership. The subject parcel is bordered on the left by an easement to access the property directly behind the subject parcel. Acquiring additional lot area would not be feasible.

5. That the proposed development is as nearly in conformance with the zoning regulations currently in effect as is reasonably possible, as the proposed project will comply with all applicable zoning regulations with the exception of non-conforming floor area increase for the structure and the non-conforming location of the detached carport in the front yard.
6. That the use permit approval does not constitute a granting of special privileges, as Chapter 4 (Zoning Non-Conformities) of the San Mateo County Zoning Regulations provides the same exception process for similar parcels under the same conditions.

## **RECOMMENDED CONDITIONS OF APPROVAL**

### **Current Planning Section**

1. This approval applies only to the proposal, documents, and plans described in this report and submitted to and approved by the Zoning Hearing Officer on April 1, 2021. The Community Development Director may approve minor revisions or modifications to the project if they are consistent with the intent of and in substantial conformance with this approval.
2. This Use Permit is valid for one (1) year from the date of final approval in which time a valid building permit shall be issued. Any extension of this permit shall require submittal of an application for permit extension and payment of applicable fees sixty (60) days prior to expiration.
3. The applicant shall apply for a building permit and shall adhere to all requirements from the Building Inspection Section. Additionally, construction shall not commence until a valid building permit is issued.
4. To reduce the impact of any construction-related activities on neighboring properties, comply with the following:
  - a. All debris shall be contained on-site; a dumpster or trash bin shall be provided on-site during construction to prevent debris from blowing onto adjacent properties. The applicant shall monitor the site to ensure that trash is picked up and appropriately disposed of daily.
  - b. The applicant shall remove all construction equipment from the site upon completion of the use and/or need of each piece of equipment which shall include but not be limited to tractors, back hoes, cement mixers, etc.
  - c. The applicant shall ensure that no construction-related vehicles shall impede through traffic along Menlo Oaks Drive right-of-way. All construction vehicles shall be parked on-site outside public right-of-ways or in public

locations which do not impede safe access to Menlo Oaks Drive. There shall be no storage of construction vehicles in the public right-of-way.

5. During project construction, the applicant shall, pursuant to Chapter 4.100 of the San Mateo County Ordinance Code, minimize the transport and discharge of stormwater runoff from the construction site by:
  - a. Protecting areas not to be disturbed using a vegetative buffer strip or fence/barrier.
  - b. Covering construction materials stored on-site with a tarp or other waterproof material when not in use.
  - c. Storing, handling, and disposing of construction materials and wastes so as to avoid their entry to the storm drain system or water body.
  - d. Avoiding cleaning, fueling or maintaining vehicles on-site, except in an area designated to contain and treat runoff.
6. Noise sources associated with demolition, construction, repair, remodeling, or grading of any real property shall be limited to the hours from 7:00 a.m. to 6:00 p.m. weekdays and 9:00 a.m. to 5:00 p.m. Saturdays. Said activities are prohibited on Sundays, Thanksgiving, and Christmas (San Mateo Ordinance Code Section 4.88.360)
7. This permit does not allow for the removal of any trees. Removal of any tree with a diameter equal to, or greater than, 12 inches as measured 4.5 feet above the ground shall require a separate tree removal permit.

#### Building Section

8. A valid building permit shall be issued prior to the commencement of any work.

BRA:cmc – BRAFF0511\_WCU.DOCX



**COUNTY OF SAN MATEO - PLANNING AND BUILDING DEPARTMENT**

# **ATTACHMENT B**







**COUNTY OF SAN MATEO - PLANNING AND BUILDING DEPARTMENT**

# **ATTACHMENT C**

# Application for a Zoning Nonconformity Use Permit Site Diagram (Update)

Initial Location Considered  
at 2/11/2021 ZHO meeting.

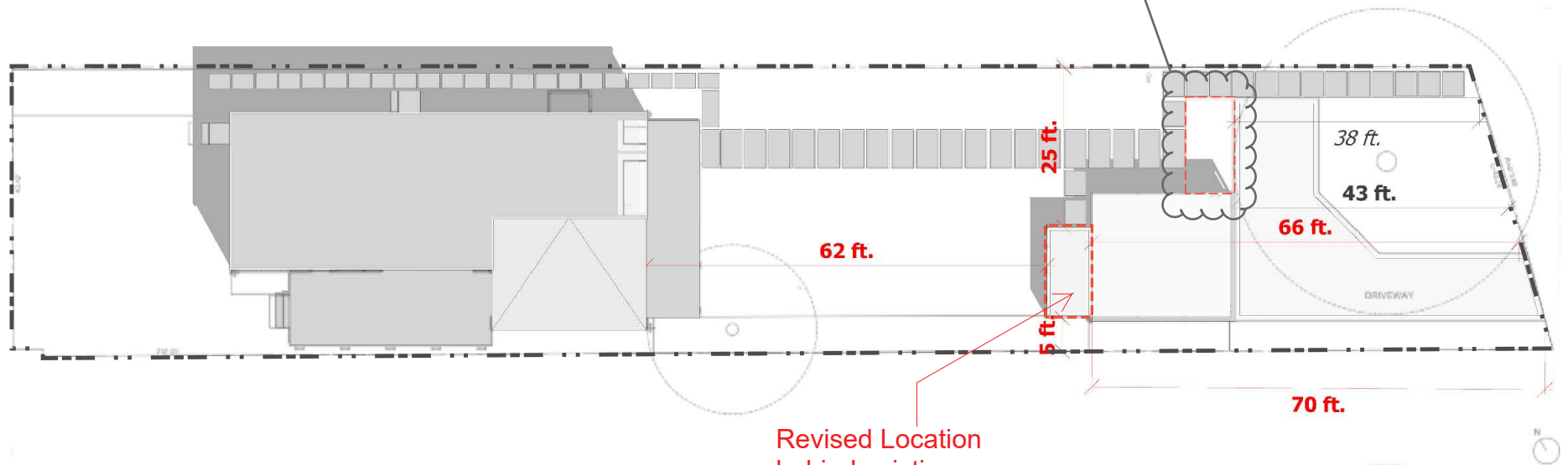

Revised Location  
behind existing  
Carport (see Attach. D  
- Street View).

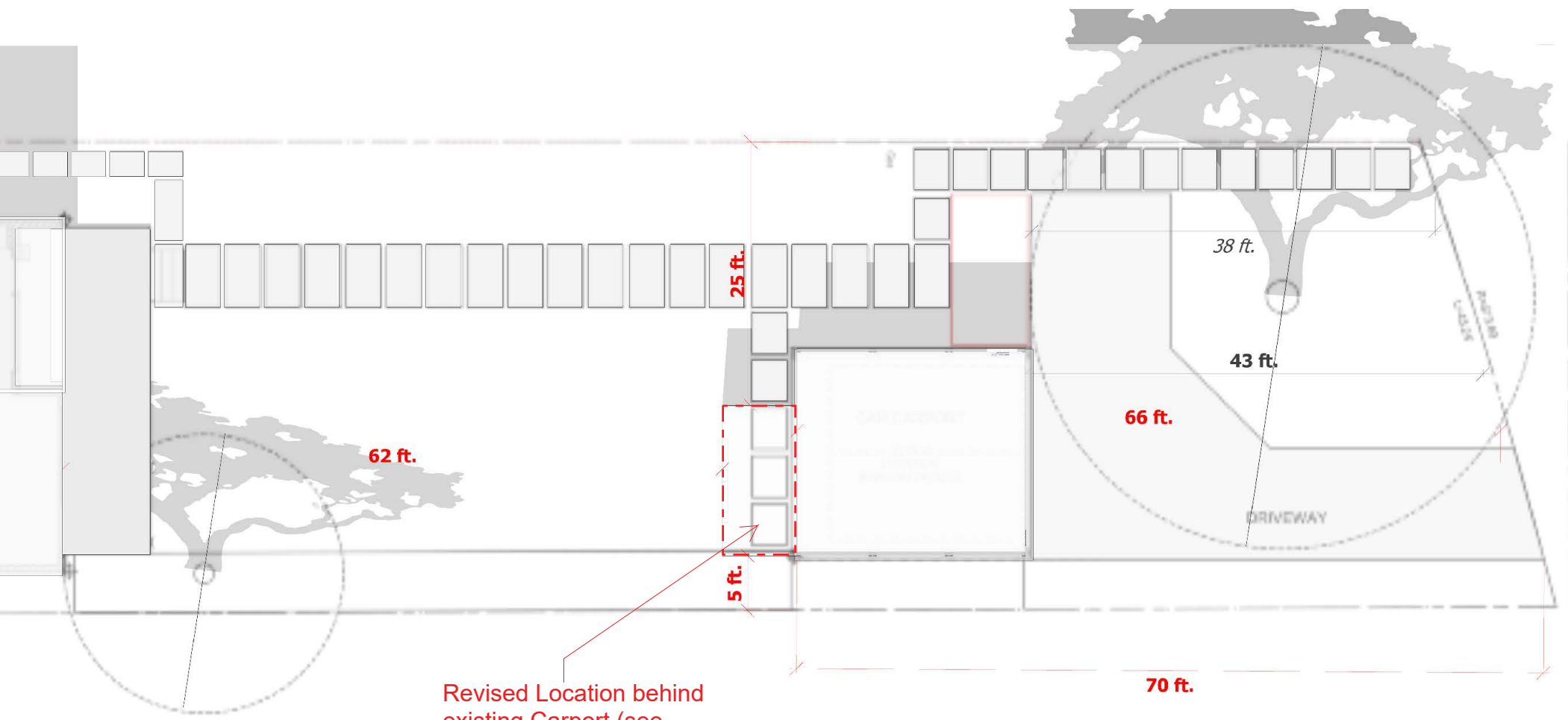

Revised Location behind existing Carport (see Attach. D - Street View).

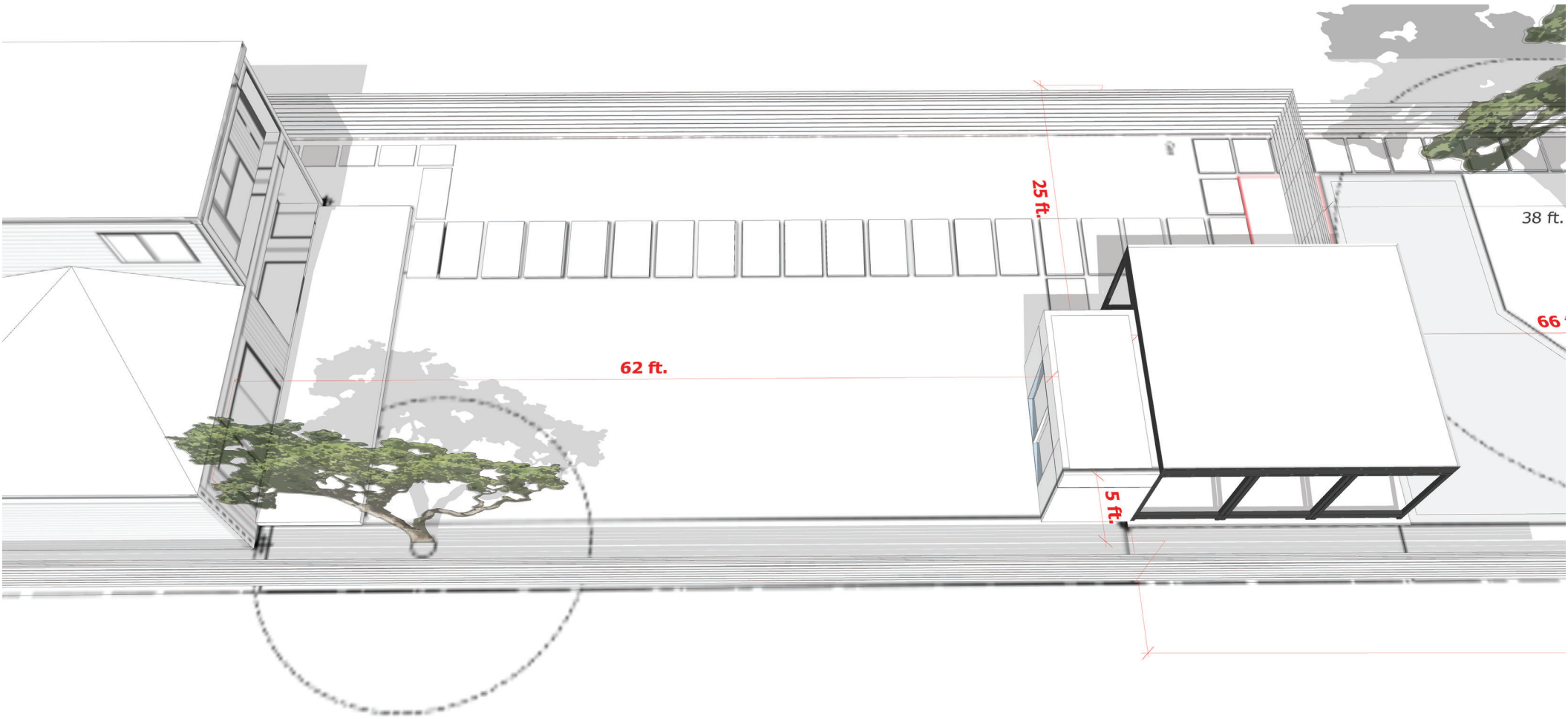

62 ft.

25 ft.

5 ft.

38 ft.

66 ft.

Front

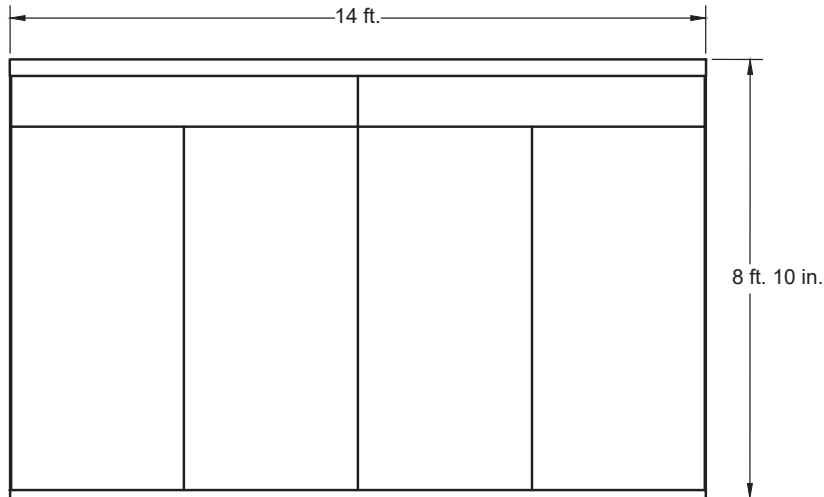

Side

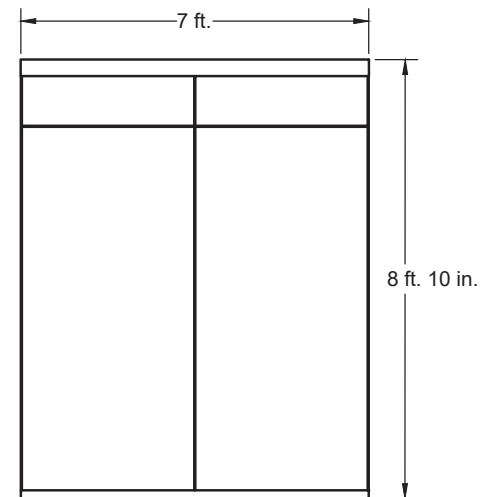

Back

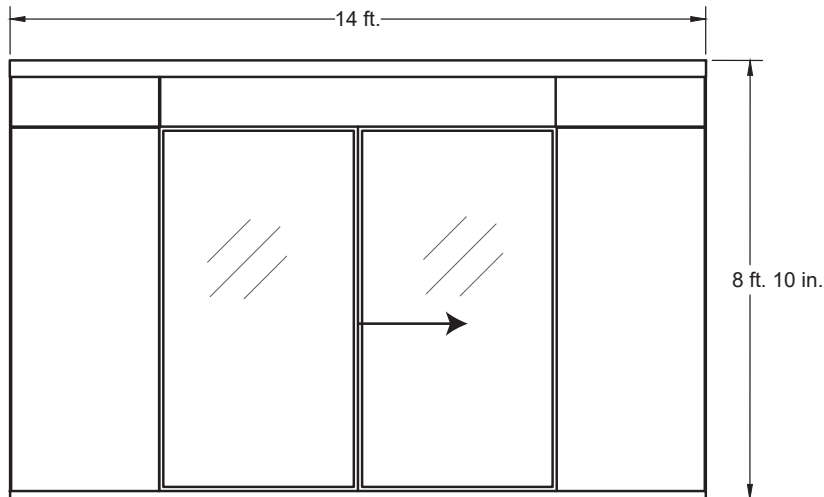

Plan

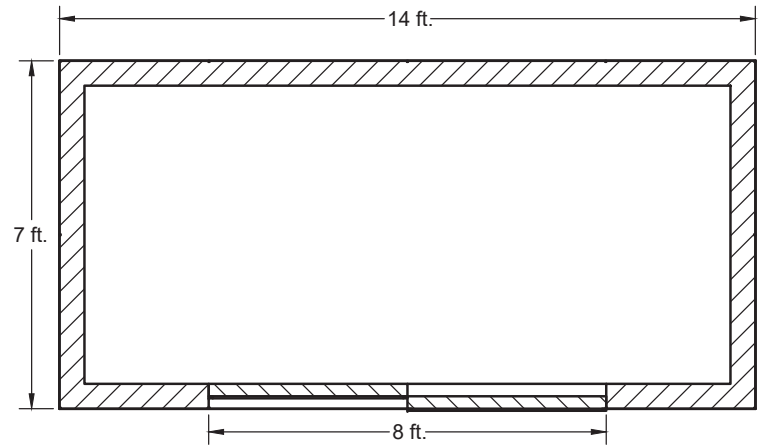

Bike Shed  
573 Menlo Oaks Drive



**COUNTY OF SAN MATEO - PLANNING AND BUILDING DEPARTMENT**

**ATTACHMENT D**



**573 MENLO OAKS DRIVE (FEBRUARY 2020)**

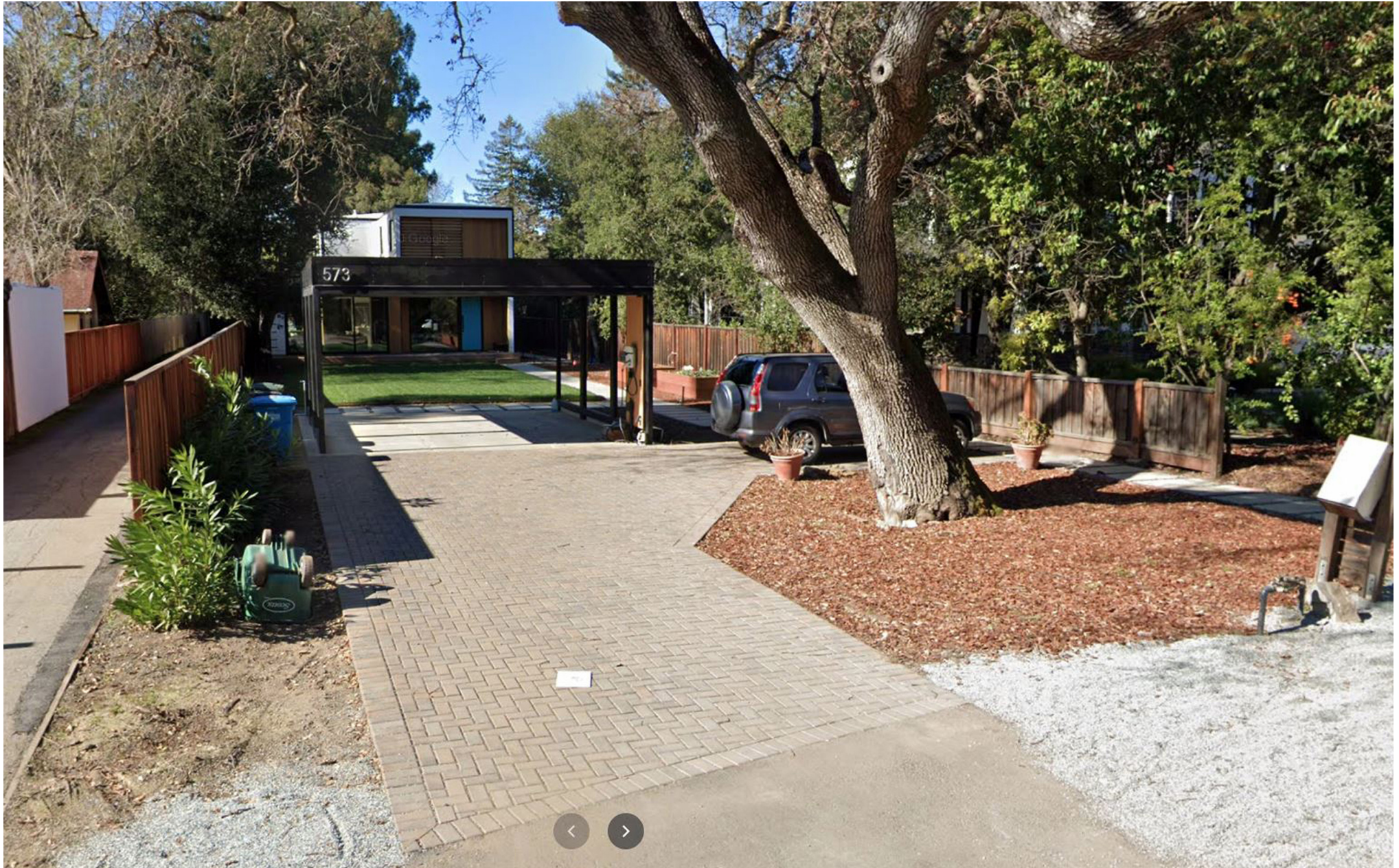



**573 MENLO OAKS DRIVE (PROPOSED STORAGE STRUCTURE)**

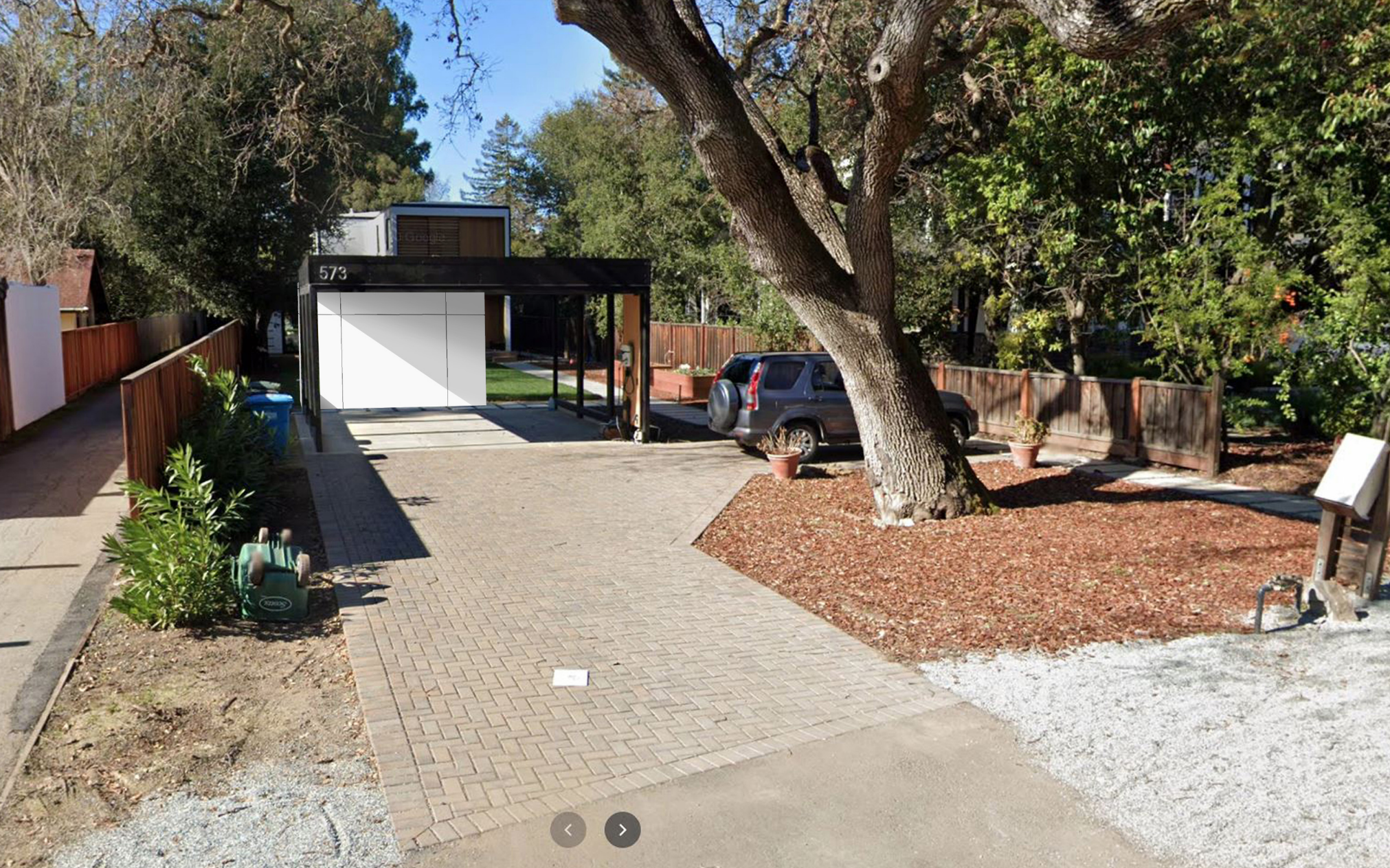





**COUNTY OF SAN MATEO - PLANNING AND BUILDING DEPARTMENT**

**ATTACHMENT E**

**COUNTY OF SAN MATEO  
PLANNING AND BUILDING DEPARTMENT**

**DATE:** February 4, 2021

**TO:** Zoning Hearing Officer

**FROM:** Planning Staff

**SUBJECT:** Consideration of a Non-Conforming Use Permit, pursuant to Section 6411 and 6137 of the County of San Mateo Zoning Regulations, to construct a bicycle storage shed in the front half of a non-conforming parcel and exceed maximum floor area ratio by 92 sq. ft. The project is located at 573 Menlo Oaks Drive in the unincorporated Menlo Oaks area of San Mateo County.

County File Number: PLN 2020-00311 (Wood)

**PROPOSAL**

The applicant proposes to construct a 98 sq. ft. bicycle storage shed adjacent to the existing two-car carport located within the front half of the non-conforming 10,133 sq. ft. parcel (where 20,000 sq. ft. is the minimum parcel size). The addition of the shed will also exceed the maximum parcel floor area ratio of 30% (3,039 sq. ft.) by 92 sq. ft. for a floor area ratio of 31% (3,130 sq. ft.). The location of the detached shed does not conform to the detached accessory building regulations that require the shed to be located in the rear half of a property. The non-conforming use permit is needed to allow for the proposed location in the front yard setback and to exceed floor area ratio. No trees are proposed for removal.

**RECOMMENDATION**

That the Zoning Hearing Officer approve the Non-Conforming Use Permit (County File Number PLN 2020-00311), by making the required findings and adopting the conditions of approval included in Attachment A.

**BACKGROUND**

Report Prepared By: Bryan Albini, Project Planner; [balbini@smcgov.org](mailto:balbini@smcgov.org)

Applicant/Owner: Danielle and Eric Wood

Location: 573 Menlo Oaks Drive, Menlo Oaks

APN: 062-140-160

Size: 10,133 sq. ft.

Existing Zoning: R-1/S-100 (Single-Family Residential District/ S-100 Combining District with 20,000 sq. ft. minimum parcel size)

General Plan Designation: Low Density Residential (0.3 to 2.3 dwelling units per acre)

Sphere-of-Influence: Menlo Park

Existing Land Use: Single-Family Residence

Water Supply: California Water Service – Bear Gulch

Sewage Disposal: West Bay Sanitary District

Flood Zone: Zone X (Area of Minimal Flooding), Map page 06081C0308E; effective date October 16, 2012.

Environmental Evaluation: Categorically exempt from the California Environmental Quality Act (CEQA) Guidelines, pursuant to Section 15303, Class 3, related to the construction of accessory (appurtenant) structures.

Setting: The project site is located on a flat developed parcel in a residential neighborhood in Menlo Oaks, an unincorporated community adjacent to Menlo Park. There is an existing residence and detached carport in the front yard. Adjacent lands are developed with single-family residences.

Chronology:

<u>Date</u>	<u>Action</u>
May 2020	- Property owners begin construction on 98 sq. ft. bicycle shed next to existing detached carport constructed in 2020 (BLD2017-02349).
June 2020	- Construction halted after concerns from neighbor about permitting.
September 17, 2020	- Use Permit application submitted to allow for an accessory structure in the front half of a residential parcel (PLN 2020-00311).
February 4, 2021	- Zoning Hearing Officer Meeting

## DISCUSSION

### A. KEY ISSUES

#### 1. Conformance with the General Plan

Staff has determined that the proposed project complies with all applicable County General Plan policies, specifically:

Policy 4.36 (*Urban Area Design Concept*) and Policy 8.15 (*Land Use Compatibility*) seek to maintain and improve upon the appearance and visual character of development in urban areas, ensure that proposed development contributes to the orderly and harmonious nature of the locality, and protect and enhance the character of existing single-family areas.

The project involves the construction of 98 sq. ft. enclosed bicycle storage shed next to the existing detached carport in the front half of a non-conforming parcel. The structure is approximately 36 feet from the front property line, where 40 feet is the required front yard setback for structures in this zoning district. While there is no distinct design theme for this area of Menlo Oaks, surrounding development includes one- and two-story residences with a mix of stucco and wood siding, traditional and modern style roofs, and two-car garages. The construction of the proposed accessory storage structure does not change the existing single-family residential use, and will use materials and colors that complement the existing residence exterior finish.

In addition, Policy 8.35 (Zoning Regulations) and Policy 8.36 (Uses) aims to regulate urban uses by providing development standards that are consistent with the overall land use designation. The proposed accessory structure will be compatible with the neighborhood and adhere to all applicable regulations with the exception of the side yard setbacks and parcel floor area.

#### 2. Conformance with the Zoning Regulations

The project conforms with the following applicable Zoning Regulations:

##### a. Development Standards

The project parcel is zoned R-1/S-100 (Single-Family Residential District/S-100 Combining District). The legal 10,133 sq. ft. parcel is non-conforming for lot width and building lot area and is improved with a 3,032 sq. ft. two-story residence and 400 sq. ft. detached carport. The residence and carport were approved under a previous use permit (PLN2016-00104) to allow for reduced side yard setbacks and the detached carport in the front half of the parcel that was completed in early 2020 (BLD2017-02349). The proposed 98 sq. ft. bicycle storage building will be non-conforming for the location in the front half of the residential parcel and will increase the total calculated floor area on the

parcel to exceed the maximum allowed by 0.8% to 3,130 sq. ft. (where 3,039 sq. ft. is the maximum allowed for a parcel of this size). The proposed development would otherwise comply with all other required development standards for the R-1/S-100 Zoning District as outlined in the tables below.

S-100 District Development Standards			
	Required	Existing	Proposed
Minimum Lot Width	Average 75 ft.	43.42 ft.*	<i>No Change</i>
Minimum Building Area	20,000 sq. ft.	10,133 sq. ft.*	<i>No Change</i>
Minimum Front Yard Setback	40 ft.	125 ft. 5 in.	<i>No Change</i>
Minimum Side Yard Setback	10 ft.	4 ft.* (Left) 6 ft. 6 in.* (Right)	<i>No Change</i>
Minimum Rear Yard Setback	20 ft.	33 ft. 8 in.	<i>No Change</i>
Maximum Lot Coverage <sup>1</sup> (All Development)	25% (2,533 sq. ft.)	22% (2,278 sq. ft.)	23% (2,374 sq. ft.)
Maximum Floor Area Ratio <sup>2</sup> (All Development)	30% (3,039 sq. ft.)	29% (3,032 sq. ft.)	31% (3,130 sq. ft.)
Maximum Building Height	30 ft.	20 ft. 10 ¾ in.	<i>No Change</i>
<p><i>*Non-conforming.</i></p> <p>1. Lot Coverage includes residence (1,878 sq. ft.) and detached carport (400 sq. ft.) with proposed accessory structure (94 sq. ft.).</p> <p>2. Floor Area Ratio calculation includes residence (3,032 sq. ft.) and proposed accessory structure (94 sq. ft.). Detached carport (400 sq. ft.) and sub-grade basement (303 sq. ft.) not included.</p>			

Detached Accessory Building Development Standards			
	Required	Existing Carport	Proposed Shed
Maximum Floor Area of Rear Yard Area	30% (1,519 sq. ft.)	7% (400 sq. ft.) In Front Yard	9% (498 sq. ft.) In Front Yard**
Maximum Floor Area	1,000 sq. ft.	400 sq. ft.	498 sq. ft.
Maximum Plate Height	10 ft.	9 ft.	8 ft. 10 in.
Minimum Front Yard Setback	Not Allowed	40 ft.	36 ft.
Minimum Left Side Yard Setback	3 ft.	19 ft. 7 in.	5 ft.
Minimum Right Side Yard Setback	3 ft.	5 ft.	5 ft.
Minimum Rear Yard Setback	3 ft.	164 ft.	183 ft.
Minimum Distance From Residence	5 ft.	68 ft. 10 in.	83 ft. 8 in.
<p><i>**Proposal requiring a non-conforming use permit.</i></p>			

The S-100 Zoning District development standards require that the maximum allowed floor area for a parcel exceeding 10,000 sq. ft. is 30%, or 3,039 sq. ft. Section 6411(b) from Chapter 22 (General Provisions and Exceptions) of the San Mateo County Zoning Regulations also requires detached accessory buildings to be located in the rear half of the parcel. With the exception of the location of the storage structure, and the floor area exceeding the maximum allowed in the district by 92 sq. ft., the project meets applicable zoning regulations.

As mentioned above, the property owners began construction on the accessory structure in May 2020 without permits to store bicycles securely next to the existing carport without verifying lot coverage and location constraints required by zoning regulations. The applicants, in an attempt to bring the structure in compliance with all applicable regulations are requesting a non-conforming use permit for the detached storage structure location in the front yard and to exceed maximum floor area allowed, due to the non-conforming width and size of the parcel.

3. Conformance with Non-Conforming Use Permit Regulations

The subject parcel is non-conforming as identified in Section 2.a. above., Section 6137 (*Exceptions*) allows applicants to request a non-conforming use permit to construct new development that does not conform with the zoning regulations, as is being proposed under the subject application. Therefore, the following findings, as required by Section 6137, must be made:

**a. That the proposed development is proportioned to the size of the parcel on which it is being built.**

The subject property is a legal parcel of substandard size for the S-100 Zoning District, and was improved with a 3,032 sq. ft. single-family residence, under the maximum floor area allowed of 3,039 sq. ft.

As discussed in 2.a., the proposed 98 sq. ft. detached accessory structure is non-conforming due to its location in the front yard. The applicants chose this location to due to proximity to the existing carport and the ability to accessibly store and secure bicycles and equipment.

Aside from the bicycle storage structure location and the increase in allowable floor area, the proposed development is proportional with the lot coverage limits and setbacks required by the applicable zoning district.

**b. That all opportunities to acquire additional contiguous land in order to achieve conformity with the zoning regulations currently**

**in effect have been investigated and proven to be infeasible.**

Surrounding properties are currently developed and used as single-family residences and are under separate ownership. The subject parcel is bordered on the left by an access easement serving the flag lot property directly behind the subject parcel, while the parcel to the right is a non-conforming parcel of substandard size improved with a structure with conforming side yard setbacks. Acquiring additional lot area to make the project compliant would not be feasible, nor would it address the location criteria of the accessory structure.

- c. That the proposed development is as nearly in conformance with the zoning regulations currently in effect as is reasonably possible.**

The proposed project is nearly in compliance with the applicable zoning regulations as is reasonably possible. Despite exceeding allowable floor area in the district by 92 sq. ft., the accessory structure will serve only as a bicycle storage building next to the existing carport, and no change to total habitable floor space will occur. While there is sufficient space in the rear yard to place the detached structure in compliance with Section 6411(b), the location of the detached structure in the front yard allows the residents to securely store bicycles next to the vehicles under the existing carport.

- d. That the establishment, maintenance and/or conducting of the use will not, under the circumstances of the particular case, result in a significant adverse impact to coastal resources, or be detrimental to the public welfare or injurious to property or improvements in said neighborhood.**

As proposed and conditioned, Staff has determined that the proposed detached accessory structure does not impact the public welfare or cause detriment to property or improvements in the neighborhood. The increased floor area incurred by the detached storage building is feasible due to no net increase in habitable floor area, and due to its non-conforming width and size, the property does not have an enclosed garage for storage as neighboring properties do.

Furthermore, the project site is not located within the Coastal Zone and therefore does not generate a significant adverse impact to coastal resources.

- e. That the use permit approval does not constitute a granting of special privileges.**

Approval of a non-conforming use permit does not constitute the

granting of a special privilege as Chapter 4 (*Zoning Non-Conformities*) of the San Mateo County Zoning Regulations provides the same exception process for similar properties under the same development constraints. The parcels in the area are a mixture of rectangular and flag lots, with most not meeting minimum lot width and sizes required by the district.

B. ENVIRONMENTAL REVIEW

This project is categorically exempt from the California Environmental Quality Act (CEQA) Guidelines, pursuant to Section 15303, Class 3, related to the construction of accessory (appurtenant) structures on a site in an urbanized area, zoned for residential use.

C. REVIEWING AGENCIES

Building Inspection Section

**ATTACHMENTS**

- A. Recommended Findings and Conditions of Approval
- B. Vicinity Map
- C. Project Plans
- D. Site Photos

BRA:cmc – BRAFF0511\_WCU.DOCX



County of San Mateo  
Planning and Building Department

**RECOMMENDED FINDINGS AND CONDITIONS OF APPROVAL**

Permit or Project File Number: PLN 2020-00311      Hearing Date: February 4, 2020

Prepared By: Bryan Albin,  
Project Planner

For Adoption By: Zoning Hearing Officer

**RECOMMENDED FINDINGS**

For the Environmental Review, Find:

1. That the project is categorically exempt from the California Environmental Quality Act (CEQA) Guidelines, pursuant to Section 15303, Class 3, related to the construction of accessory (appurtenant) structures on a site in an urbanized area, zoned for residential use.

For the Non-Conforming Use Permit, Find:

2. That the establishment, maintenance and/or conducting of the use will not, under the circumstances of the particular case, result in a significant adverse impact to coastal resources, or be detrimental to the public welfare or injurious to property or improvements in said neighborhood, as the site is not located within the Coastal Zone and the proposed project generates negligible impacts on adjacent parcels and the surrounding neighborhood. The front yard location and floor area increase will allow for a proportionately sized bicycle storage building, offering transportation alternatives to the residents.
3. That the proposed development is proportioned to the size of the parcel on which it is being built, as the decreased setbacks allow for minimized visual impact and the location of the carport allows for the proposed residence to be of proportional size to the substandard parcel. The proposed structure complies with maximum lot coverage limits of the applicable zoning district.
4. Surrounding properties are currently developed and used as single- family residences and are under separate ownership. The subject parcel is bordered on the left by an easement to access the property directly behind the subject parcel. Acquiring addition lot area would not be feasible.

5. That the proposed development is as nearly in conformance with the zoning regulations currently in effect as is reasonably possible, as the proposed project will comply with all applicable zoning regulations with the exception of non-conforming floor area increase for the structure and the non-conforming location of the detached carport in the front yard.
6. That the use permit approval does not constitute a granting of special privileges, as Chapter 4 (Zoning Non-Conformities) of the San Mateo County Zoning Regulations provides the same exception process for similar parcels under the same conditions.

### **RECOMMENDED CONDITIONS OF APPROVAL**

#### Current Planning Section

1. This approval applies only to the proposal, documents, and plans described in this report and submitted to and approved by the Zoning Hearing Officer on February 4, 2021. The Community Development Director may approve minor revisions or modifications to the project if they are consistent with the intent of and in substantial conformance with this approval.
2. This Use Permit is valid for one (1) year from the date of final approval in which time a valid building permit shall be issued. Any extension of this permit shall require submittal of an application for permit extension and payment of applicable fees sixty (60) days prior to expiration.
3. The applicant shall apply for a building permit and shall adhere to all requirements from the Building Inspection Section. Additionally, construction shall not commence until a valid building permit is issued.
4. To reduce the impact of any construction-related activities on neighboring properties, comply with the following:
  - a. All debris shall be contained on-site; a dumpster or trash bin shall be provided on-site during construction to prevent debris from blowing onto adjacent properties. The applicant shall monitor the site to ensure that trash is picked up and appropriately disposed of daily.
  - b. The applicant shall remove all construction equipment from the site upon completion of the use and/or need of each piece of equipment which shall include but not be limited to tractors, back hoes, cement mixers, etc.

- c. The applicant shall ensure that no construction-related vehicles shall impede through traffic along Alameda De Las Pulgas and Sterling Avenue right-of-ways. All construction vehicles shall be parked on-site outside public right-of-ways or in public locations which do not impede safe access on Alameda De Las Pulgas and Sterling Avenue. There shall be no storage of construction vehicles in the public right-of-way.
5. During project construction, the applicant shall, pursuant to Chapter 4.100 of the San Mateo County Ordinance Code, minimize the transport and discharge of stormwater runoff from the construction site by:
  - a. Protecting areas not to be disturbed using a vegetative buffer strip or fence/barrier.
  - b. Covering construction materials stored on-site with a tarp or other waterproof material when not in use.
  - c. Storing, handling, and disposing of construction materials and wastes so as to avoid their entry to the storm drain system or water body.
  - d. Avoiding cleaning, fueling or maintaining vehicles on-site, except in an area designated to contain and treat runoff.
6. Noise sources associated with demolition, construction, repair, remodeling, or grading of any real property shall be limited to the hours from 7:00 a.m. to 6:00 p.m. weekdays and 9:00 a.m. to 5:00 p.m. Saturdays. Said activities are prohibited on Sundays, Thanksgiving, and Christmas (San Mateo Ordinance Code Section 4.88.360)
7. This permit does not allow for the removal of any trees. Removal of any tree with a diameter equal to, or greater than, 12 inches as measured 4.5 feet above the ground shall require a separate tree removal permit.

Building Section

8. A valid building permit shall be issued prior to the commencement of any work.

BRA:cmc – BRAFF0511\_WCU.DOCX



**COUNTY OF SAN MATEO - PLANNING AND BUILDING DEPARTMENT**

# **ATTACHMENT B**





COUNTY OF SAN MATEO - PLANNING AND BUILDING DEPARTMENT

# ATTACHMENT C

# Application for a Zoning Nonconformity Use Permit Site Diagram

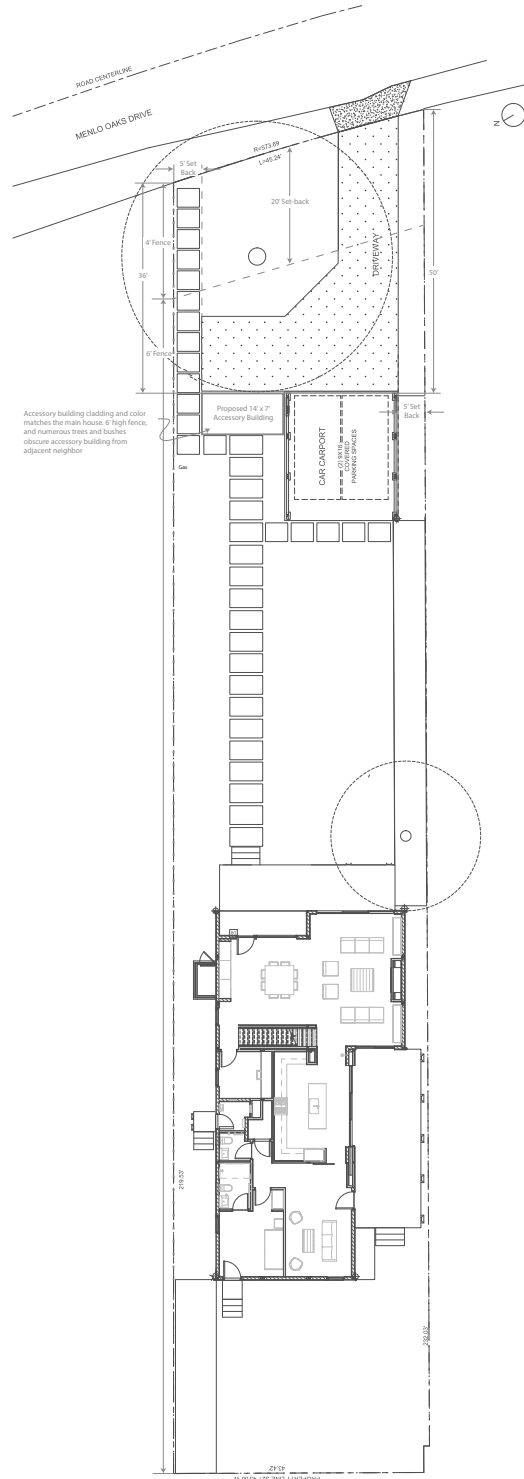

Accessory building cladding and color matches the main house, 6' high fence, and numerous trees and bushes obscure accessory building from adjacent neighbor

August 16, 2020  
573 Menlo Oaks Dr.  
Menlo Park, CA

# Application for a Zoning Nonconformity Use Permit Site Diagram

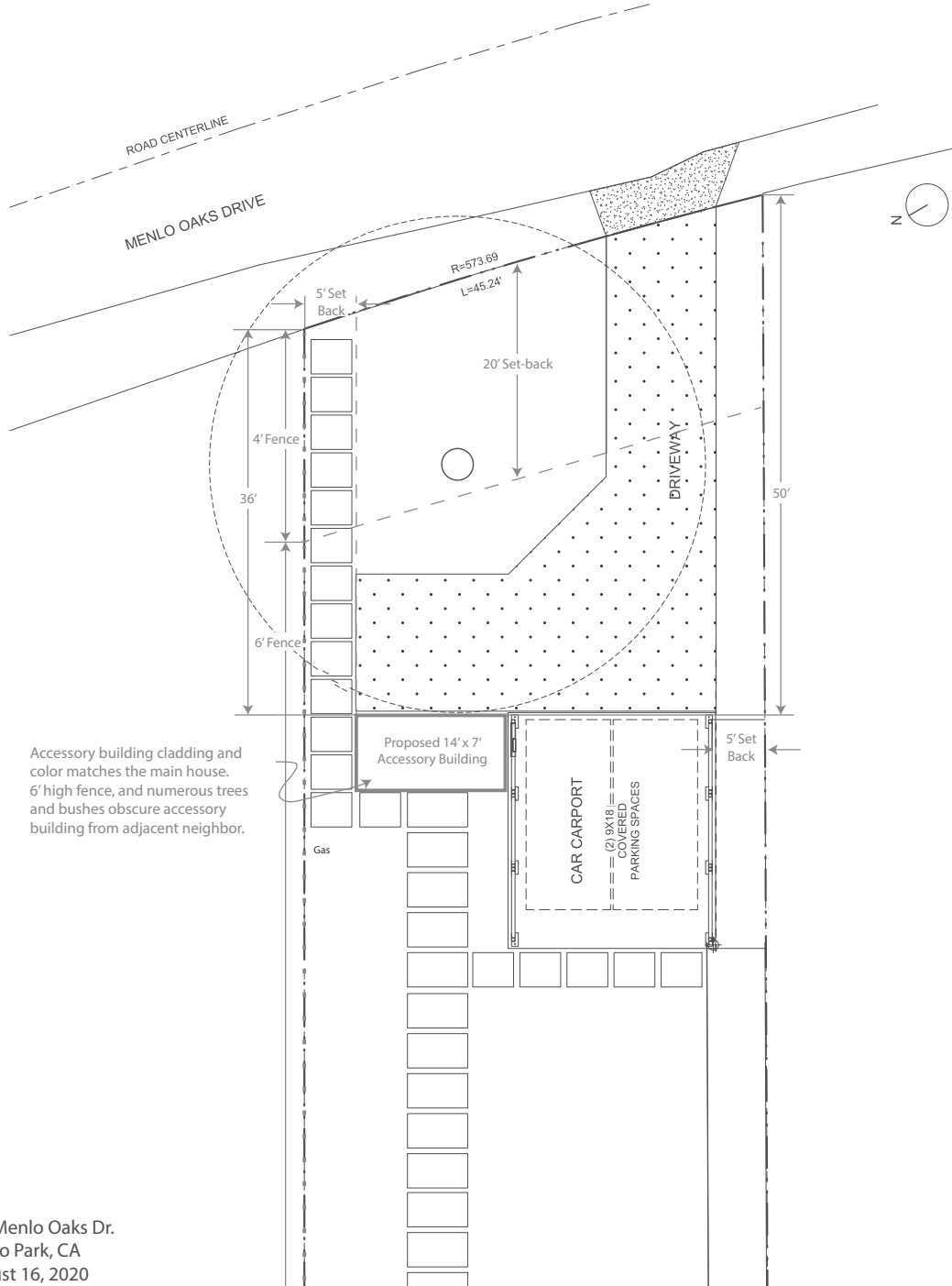

573 Menlo Oaks Dr.  
Menlo Park, CA  
August 16, 2020



Front

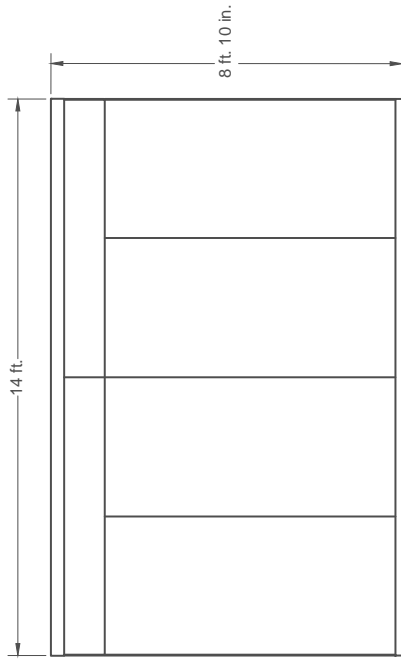

Side

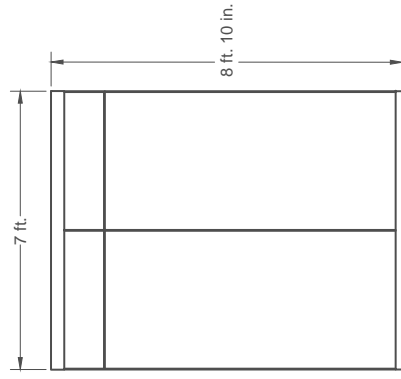

Back

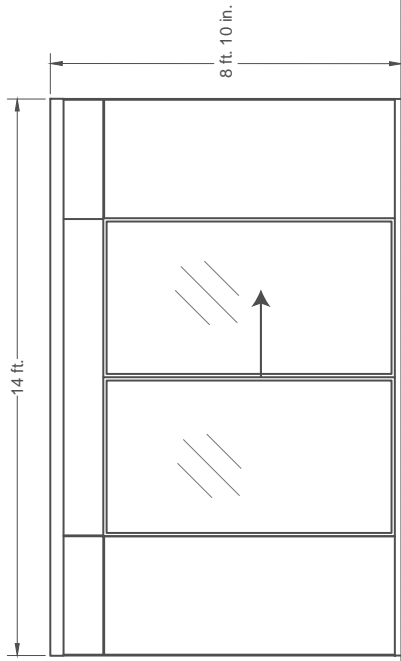

Plan

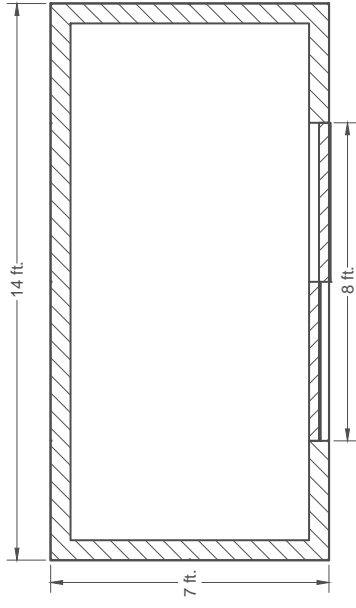

Bike Shed  
573 Menlo Oaks Drive



COUNTY OF SAN MATEO - PLANNING AND BUILDING DEPARTMENT

# ATTACHMENT D

573 MENLO OAKS DRIVE (FEBRUARY 2020)



**573 MENLO OAKS DRIVE (CURRENT CONDITIONS)**



**573 MENLO OAKS DRIVE (CURRENT CONDITIONS)**

